

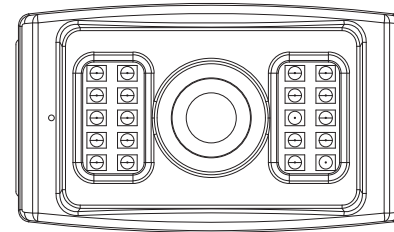



**NTSC SYSTEM VCMS20**



**VCMS20 Features:**

- High Performance CMOS Sensor
- IR LED Low Light Enhancement
- Waterproof (IPX6)
- Wide View Angle
- Audio microphone

**Camera to bracket hardware**

Specifications	Q'ty
 Hex Socket Head M4 X 8L Stainless screws	4
 Flat washer 4.5 X 9.5 X 1mm Stainless	4
 Spring washer 6.6X4.0X1.0mm Stainless	4

Specifications	Q'ty
 Allen	1

**Installation**

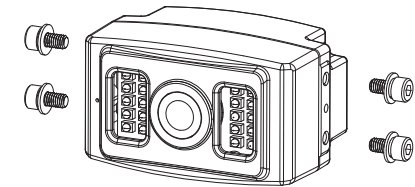

**Screw For Use**

Hex Socket Head M4 X 8L Stainless screws  
Stainless Allen wrench

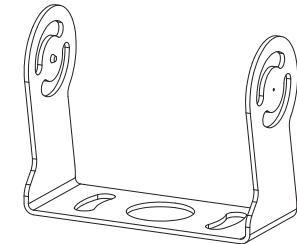

### Contents:

- Camera
- Bracket
- Hardware Kit

### Installation and Pin Out:

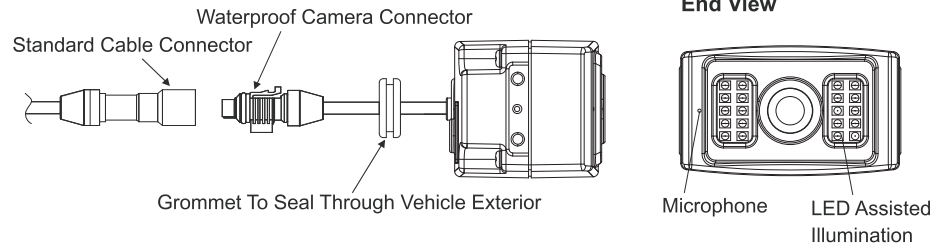

### Specifications

Mounting Type	External type
Image sensor	1/3" CMOS camera
Resolution	600 TV lines
Min illumination	1.0 Lux at F2.0 0 Lux with IR on
Water resistance	IP69K
View angle	115(H),90(V),150(D)
Dimension	68.8(W)X40.9(H)X46.2(D)mm 2.75(W)X1.61(H)X1.82(D)Inch
Working temperature	-40C ~ +85C
Weight	Approx. 0.25kg / 0.42lbs

1

6

### Bracket Mtg. Hole Dimensions

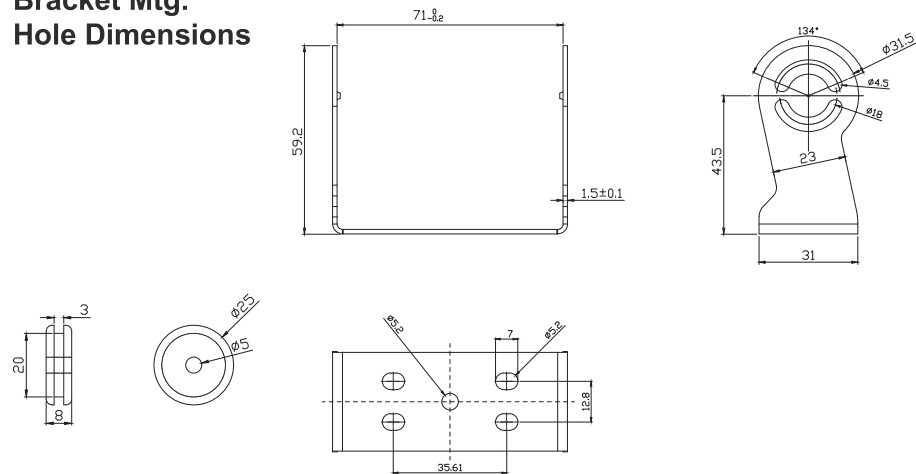

### Recommended grommet Hole

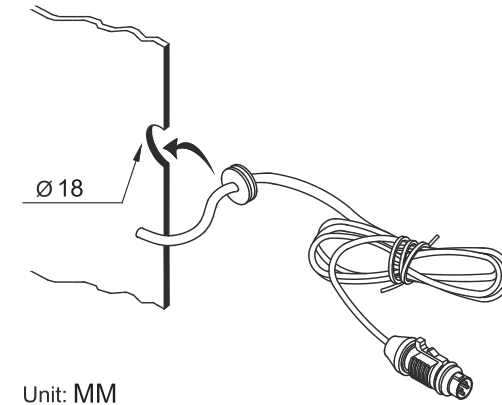

3

4