

VCAHD140LWT/VCAHD140RWT - Manual - V1.0 09/28/2021

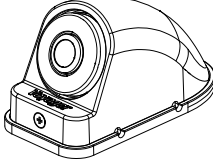

NTSC SYSTEM VCAHD140LWT/VCAHD140RWT



VCAHD140LWT/VCAHD140RWT Features:

- High Performance CMOS Sensor
- IR LED Low Light Enhancement
- Waterproof (IP69K)
- Compact Size

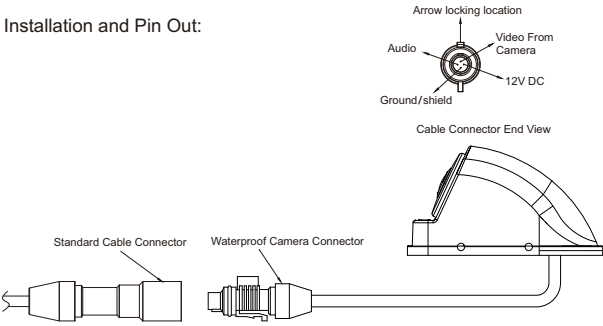

Installation and Pin Out:



Specifications

| | |
|---------------------|---|
| Mounting Type | External Type |
| Image Sensor | 1/3 CMOS |
| Resolution | 700 TV Lines |
| Min Illumination | 0 Lux (with IR LED ON) |
| Waterproof Rate | IP69K |
| View Angle | 115(H), 90(V), 150(D) |
| Dimension | 69.9(W) * 36.1(H) * 43.6 mm 2.74(W) * 1.42(H) * 1.72(D) Inch |
| Working Temperature | -40C ~ +85C |
| Weight | Approx. 0.8kg/1.76lbs |

Camera to bracket hardware

| Specifications | QTY |
|---|-----|
|  Tapping Screw M3*8mm stainless | 1 |
|  Flat Head self tapping screw M3*12mm | 4 |

Installation
Pre-drill holes with a 1/8" bit

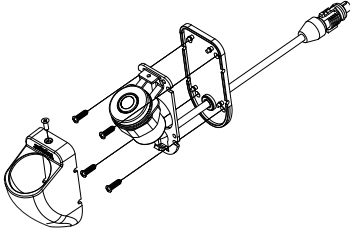

*When using spacer, be sure to use liquid sealant around spacer to prevent water intrusion into the vehicle

**Bracket Mtg.
Hole Dimensions**

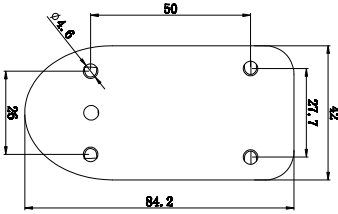

Unit : mm

