



5.25" Coaxial Waterproof Speakers

[MS5250B]



KEY FEATURES:

- Shallow mounting depth of 1"
- 36 Watts
- Integrated black grille
- Sensitivity: 85dB
- Frequency: 70Hz-20kHz
- Nominal impedance: 4 Ohms
- Polypropylene woofer
- Suspension/surround: Rubber
- Voice coil size: 1"
- Magnet: 5.3 oz.
- Mounting hole diameter: 4.5"
- Mounting depth: 1"
- Corrosion resistant finishes/materials (ASTM B117)
- UV resistant finishes/materials (ASTM D4329)

PRELIMINARY

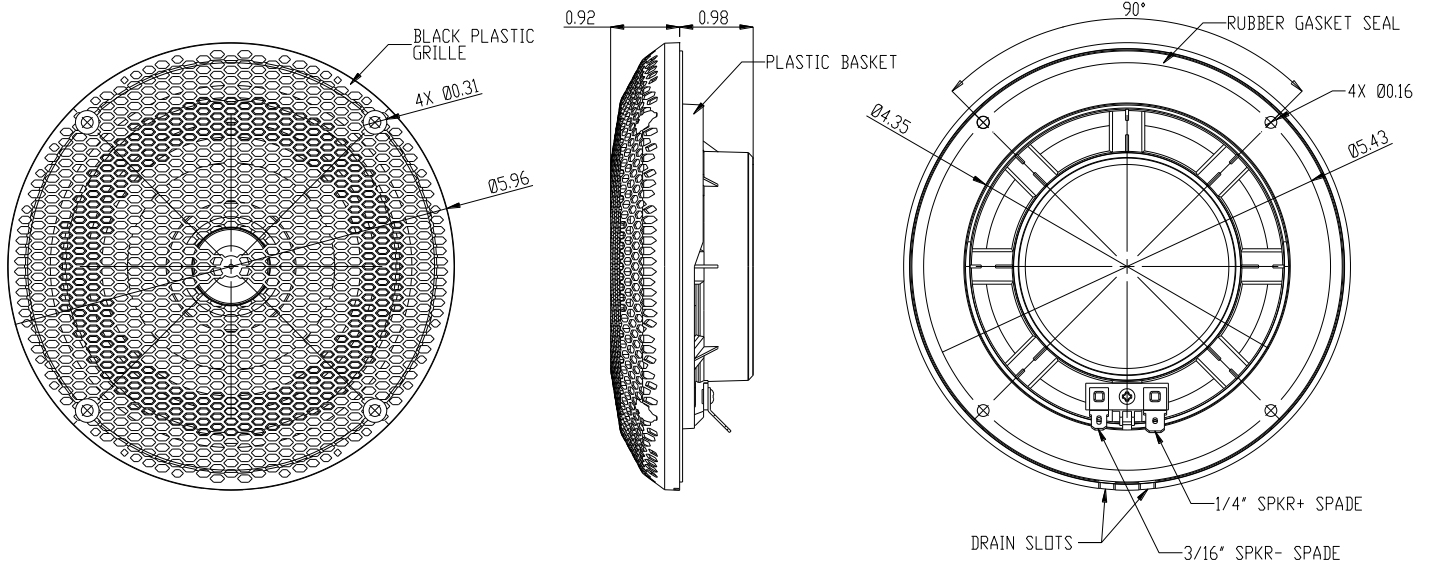

Specifications:		
General Specifications:		
Woofer Size	5.25"	
Woofer Material	Polypropylene	
Suspension / Surround	Rubber	
Tweeter Type	TBD	
Tweeter Material	TBD	
Voice Coil Size	1.02"	
Magnet Weight	5.3 Oz	
Mounting Depth	1"	
Hole Size	4.5"	
Impedance	4 ohm	
Max RH	100%	
Temperature Range	-30°C - 70°C	-22°F - 158°F
Terminal Size	Positive - 1/4"	Negative -3/16"
Performance Specifications:		
Frequency Response	70Hz-20KHz +/- 10dB	
RMS Power Range	18W	
Max Input Power	36W	
Sensitivity (1W/1M)	85 dB	
Resonant Frequency	105 Hz	