



5" High Performance Coaxial Speaker

JXHD50HPB



PRODUCT FEATURES

- Max power: 75 watts
- Bridged/suspended tweeter
- All plastic chassis construction
- Polypropylene cone
- Rubber suspension/surround
- Gloss black grille color
- UV resistant (ASTM D4329)
- Water and corrosion resistant sealed design
- Magnet weight: 6.5 oz.
- Mounting depth: 2"

DESIGNED TO MOVE [YOU]™

asa
ELECTRONICS™
2602 Marina Drive • Elkhart, IN 46514
www.asaelectronics.com



5" High Performance Coaxial Speaker

JXHD50HPB

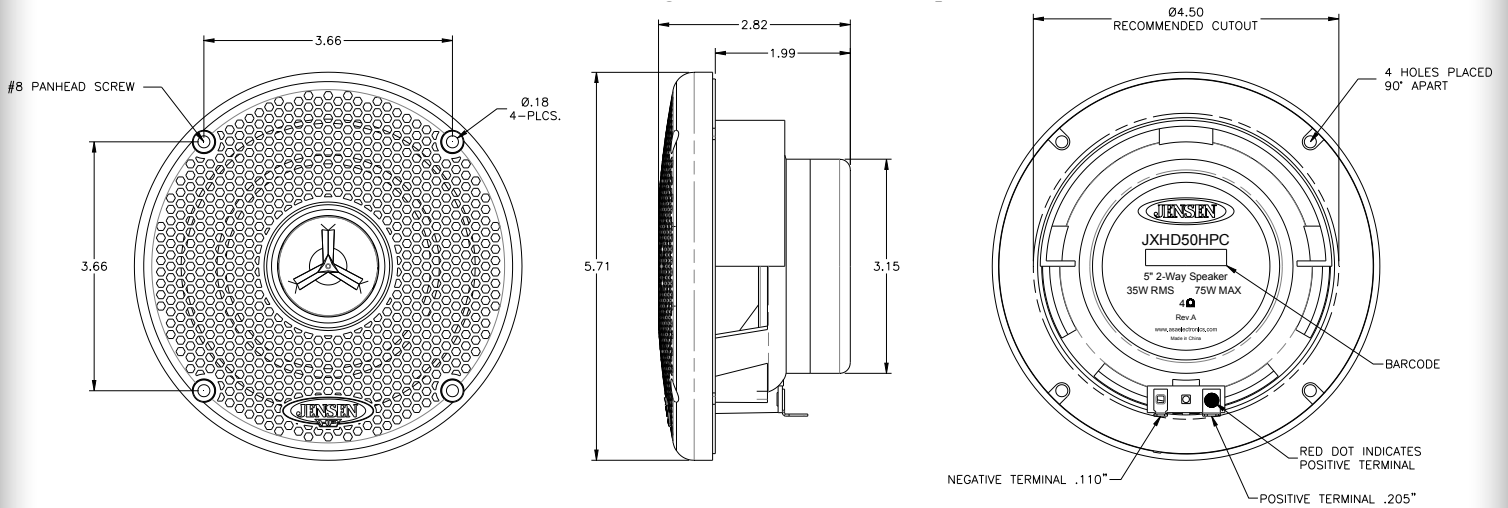

Specifications:

General Specifications:

Woofer Size	5"	
Woofer Material	Poly-propylene	
Tweeter Type	Dome	
Tweeter Material	Silk	
Voice Coil Size	1" KSV	
Magnet Weight	6.5 oz	
Mounting Depth	2"	
Hole Size	4.5"	
Impedance	4 Ω	
Temperature Range	-30°C - 70°C	-22°F - 158°F
Max RH	100%	
Terminal Size	Positive - 0.205"	Negative - 0.110"

Performance Specifications:

Frequency Response	80 Hz – 20 KHz	
RMS Power	35W	
Max Power	75W	
SPL @ 1 W/ 1 M	88 dB	
Resonant Frequency	90 Hz	